

## TUBE CUTTING MACHINE PRO 8-36 MODEL

The pneumatically powered tube cutting machine can work on site as well as in workshops conditions. The machine is driven on rail which is held on the tube to be cut by means of pressure screws. Quick set-up of the rail on the tube and set-up of the machine on the rail by means of retractable rollers.



### CAPACITY

Tube OD : 8" to 36"  
For larger diameters, please consult us.  
Thickness up to 25 mm.

### FUNCTION

Tube cutting ( outside bevel is possible ).

### FEED

Manual tool feed ( automatic on request ).

### PENETRATION

Manual control carriage ( automatic on request ).

### TOOL DRIVE

1 pneumatic drive.  
Power : 2 CV  
Torque : 30mkg  
6 bars – 2000 l/mm

### CUTTING SPEED

13 m/mm with a Ø200 milling tool

### OVERALL DIMENSIONS

See sketch

### WEIGHT

Machine without rail : 41 kg

### SET UP

5 to 10 mn set-up.

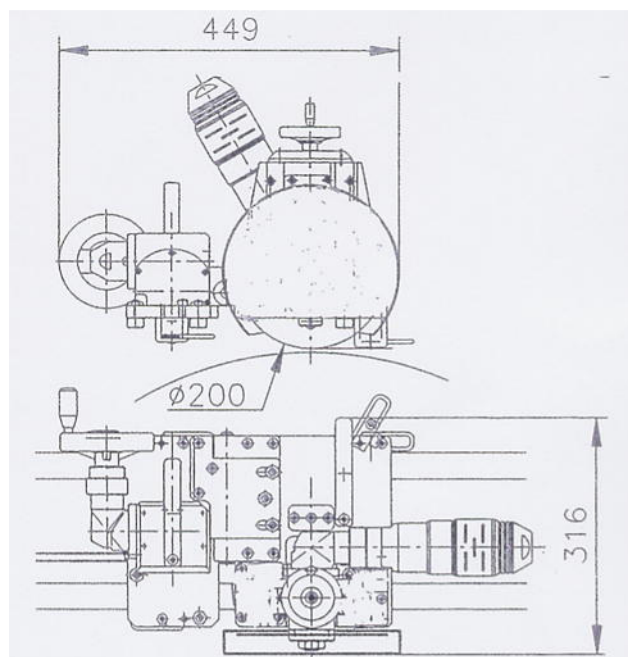

### STANDARD EQUIPMENT

The machine is delivered with :

- Ø200 circular saw blade
- Guiding rail for 12" tube ( other diameter on request )
- Set of roller supports for 12" rails
- Set of tools
- Packing and transport crate